





# HALF MOON WALL



## DESCRIPTION

HALF MOON WALL is an extremely compact LED luminaire capable of enhancing outdoor ambiances with discretion and elegance through the creation of refined accent lighting effects. Its external power supply unit allows a comfortable installation even in the smallest spaces, as well as the simultaneous management of multiple units. It is the ideal solution for a bright illumination of essential landscape or architectural details in delicate pastel tones or intense white shades.

## MAIN FEATURES

- Max. delivered lm output: 275 lm / 92 lm/W
- Size: (HxWxD) Ø 32 70x50x50/55 mm / Ø 1.26 2.76x1.97x1.97/2.16"
- Control system: DMX-RDM, DALI, ON-OFF, 0-10V, remote wireless data
- Extremely compact LED luminaire for a bright illumination of essential landscape or architectural details

## LED COLOUR CONFIGURATIONS



# HALF MOON WALL

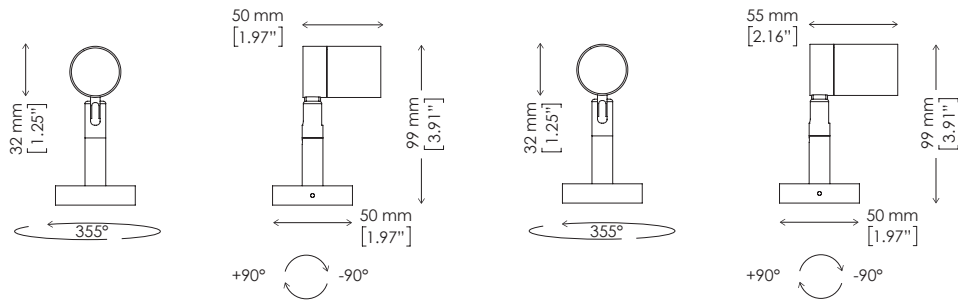

RGBW/DW

W

## FEATURES



DMX - RDM

DALI

ON - OFF



0 - 10 V

CLASS

IP67



IK07

0.2 KG



## OPTIONS

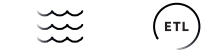

ANTI-SALINE

ETL PENDING

## LED COLOUR CONFIGURATIONS



RGB+W  
3000K

RGB+W  
4000K

DW  
2700/6500K



WARM  
WHITE 2700K

WARM  
WHITE 3000K

NATURAL  
WHITE 4000K

## FINISHES



BLACK  
RAL9005

ANTHRACITE  
RAL7016

GREY  
RAL9006



WHITE  
RAL9003

OLIVE GREY  
RAL7002

RAL ON  
REQUEST

## MORE INFO



## CODES

AL5318 HALF MOON WALL

PERFORMANCE	WATT	MAX LM OUTPUT	LM/WATT
HALF MOON WALL RGBW	3.5	54	15
HALF MOON WALL DW	3.5	92	26
HALF MOON WALL W	3	275	92

BEAM ANGLE REFERENCE	RGBW/DW	W
OPALINE DIFFUSER	120°	–
NARROW	–	12°
MEDIUM	–	23°
WIDE	–	43°
ELLIPTICAL	–	14°x38°





HALF MOON WALL

Photorealistic 3D rendering of a typical product installation